

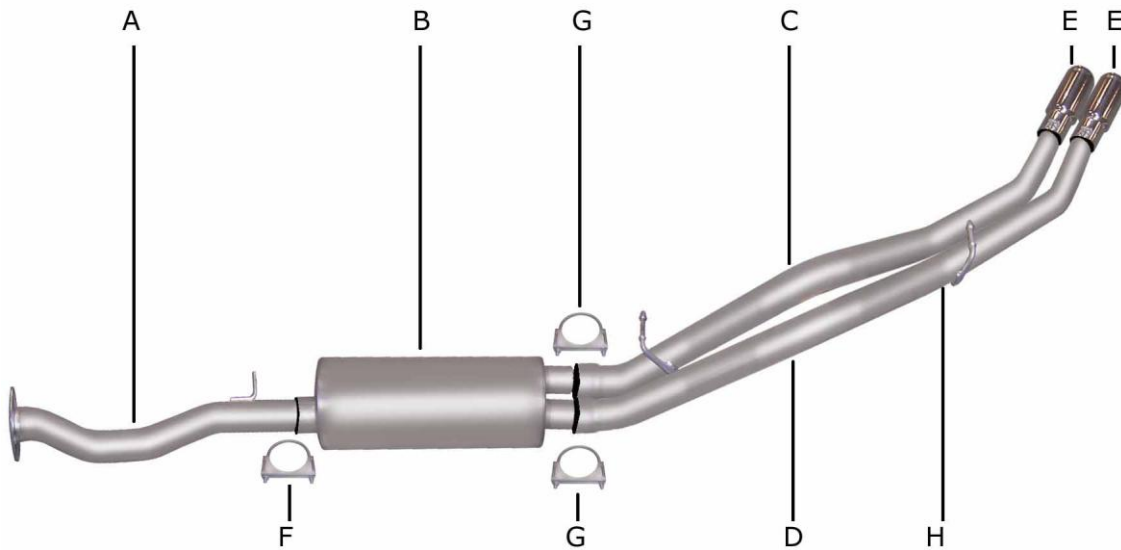

PERFORMANCE EXHAUST SYSTEMS

**INSTRUCTION MANUAL  
CAT-BACK DUAL SPORT EXHAUST  
SUBURBAN 5.7L 2WD  
PART# 5604**



ITEM	PART #	QUANTITY	DESCRIPTION
A	700105	1	HEADPIPE W/FLANGE GP-105
B	758300	1	SUPERFLOW MUFFLER
C	700326	1	2-1/4" OVERAXLE TAILPIPE
D	700327	1	2-1/4" OVERAXLE TAILPIPE
E	500370	2	3" TIPS
F	OHD300	1	3" CLAMP
G	5756	2	2-1/4" CLAMP
H	BO-906	1	BOLT KIT FOR TAILPIPE
I	BO-1028	1	BOLT KIT FOR HEADPIPE FLANGE

Thank you for purchasing our GIBSON EXHAUST SYSTEM for your vehicle. If you need further assistance, please do not hesitate to call our Technical Department at 800-528-3044, Monday through Friday, 8:00 am to 5:00 PM.

# EXHAUST INSTALLATION #5604

WHEN INSTALLING THIS EXHAUST SYSTEM MAKE SURE TO USE ALL THE PROPER SAFETY PRECAUTIONS. USE JACK STANDS WHEN UNDER TRUCK, SET PARKING BRAKE, BLOCK TIRES AND USE SAFETY GLASSES. DO NOT WORK WITH HOT PIPES!

## SUGGESTED TOOLS:

9/16" SOCKET, 1/2" WRENCH, 1/2" SOCKET, 15mm SOCKET, JACK STAND, HI-TEMP GASKET SEALER

LAY OUT THE GIBSON EXHAUST AND COMPARE PART NUMBERS WITH THE MANUAL.



1.) TO REMOVE EXHAUST- UNBOLT IT FROM THE 2 BOLT FLANGE LOCATED JUST BEHIND THE CATALYTIC CONVERTER. YOU WILL RE-USE THESE BOLTS. NOW CUT OFF YOUR STOCK TAILPIPE JUST BEHIND THE MUFFLER AND REMOVE. LEAVE ALL RUBBER GROMMETS ON THE HANGERS. USE WD-40 TO AID IN REMOVAL OF EXHAUST AND HANGERS.



5.) SLIP TAILPIPE #D INTO THE DRIVER SIDE OUTLET NO MORE THEN 2" AND NO LESS THEN 1". USE HANGER #G TO TIGHTEN THE CONNECTION AT THE MUFFLER OUTLET. DO NOT TIGHTEN. TOWARDS THE END OF THE PIPE THERE IS A TAB USE BOLT KIT #H TO SECURE PIPES TOGETHER. DRIVERSIDE GOES ON THE BOTTOM.



2.) INSTALL HEADPIPE #A ONTO STOCK FLANGE. SNUG UP THESE BOLTS. SLIDE HANGER INTO RUBBER GROMMET.

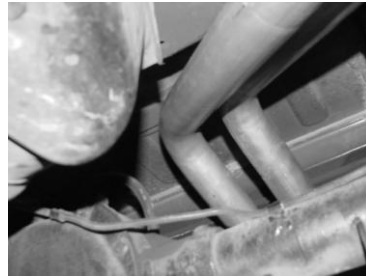

6.) ADJUST YOUR TAILPIPES TO MAKE SURE YOU HAVE A MINIMUM OF A 1" CLEARANCE ON ALL BRAKE LINES, TIRES, SHOCKS, FUEL LINES, ETC. THEN TIGHTEN ALL CLAMPS AND HANGERS STARTING FROM THE HEADPIPE BACK.



3.) SLIP MUFFLER # B ONTO HEADPIPE #A NO MORE THEN 2" AND NO LESS THEN 1" WITH THE INLET TOWARDS THE MOTOR. USE A JACK STAND TO SUPPORT THE MUFFLER. MAKE SURE THE MUFFLER OUTLETS ARE LEVEL. DO NOT TIGHTEN



7.) NEXT INSTALL YOUR STAINLESS STEEL TIPS TO YOUR DESIRED LOOK. USE ANY ALUMINUM OR STAINLESS STEEL CLEANER TO POLISH YOUR TIP.



4.) SLIP TAILPIPE #C INTO THE PASSENGER SIDE OUTLET NO MORE THEN 2" AND NO LESS THEN 1". THEN SLIP THE WELDED HANGER INTO THE FACTORY RUBBER GROMMET. USE CLAMP # G TO TIGHTEN THE CONNECTION AT THE MUFFLER OUTLET. DO NOT TIGHTEN CLAMPS.

**"MAKE SURE HAVE A MINIMUM OF A 1" ON ALL PIPES FROM ALL RUBBER BRAKE LINES, TIRES, SHOCKS, FUEL LINES, ETC."**